

# Fuzzy Control iUPQC Modeling and Construction Unit to Improve the Network of a Grid Organization

M.Bhasker<sup>1</sup>, CH.Manjula<sup>2</sup>

<sup>1, 2</sup> M.Tech, Assistant Professor

<sup>1, 2</sup> Department of EEE

<sup>1</sup>Samskruti College of Engineering & Technology, <sup>2</sup>Princeton Institute of engineering & Technology for Women, Hyderabad

Email:Manjulachenigaram@gmail.com,Bhasker.smsk@gmail.com,

**Abstract:** this paper presents an improved controller for the dual topology of the unified power quality conditioner (iUPQC) extending its applicability in power-quality compensation, as well as in grid applications. The main reason for the poor quality of energy is the harmonic currents, poor power factor, and supply voltage variations, etc. Power quality problems have received much attention these days because of their impact on both utilities and customers. Voltage sag, swell, stops for a moment, under voltages, the voltage noise and harmonics are the most common power quality disturbances. This approach provides a quality offset energy indirectly from the load voltage and source current. Using the controller, beyond the traditional power quality features UPQC, including voltage sag/swell compensation the iUPQC will also provide reactive power support to regulate not only the load-bus voltage but also the voltage at the grid-side bus. In other words, the iUPQC will work as a static synchronous compensator (STATCOM) at the grid side, while also providing compensation traditional UPQC in partial load side or network. The implementation of the proposed concept provided is to verify the new functionality of the equipment by using the MATLAB / SIMULINK program.

**Index Terms**—iUPQC, power quality, static synchronous compensator (STATCOM), Fuzzy Logic Controller, unified power quality conditioner (UPQC).

## I. INTRODUCTION

Increased use conditioners, power quality in the grid distribution system over the past years due to the steady increase in non-linear loads the electricity grid. Inexhaustible power of nonlinear loads with a high harmonic distortion voltage utility network, thereby

affecting the operation of critical loads [1-3]. Using a unified power quality conditioner (UPQC) it is possible to ensure the voltage regulated loads and balanced with low harmonic distortion at the same time drain currents undistorted network of facilities, even if the voltage and current network load our harmonic contents. UPQC two active filters, active filters series consists (SAF) and the shunt or parallel active filter (PAF). Typically is controlled PAF current source is sinusoidal, which is responsible for compensating the harmonic current of pregnancy, while the Sudanese armed forces control as a source of non-sinusoidal voltage, which is responsible for the compensation network effort. Both of them have a reference control with harmonic contents, usually; you can get these references through the complex ways [4-6]. Two Air line of single-phase inverters consists of current source which is controlled by the Sudanese armed forces by the current loop is controlled PAF by the ring effort. In this way, both the existing network and load voltage are sinusoidal, thus, indicating they are also sinusoidal. The aim of this proposal is a dual three-phase four-wire unified power quality conditioner (iUPQC) using fuzzy logic in the shunt active filter. It is to be used in networks facilities. Fuzzy logic control to allow the solution is uncertain and ambiguous problems of methodology have been demonstrated. In this paper uses fuzzy logic controller for generating switching pulses units PWM control [7]. The advantages of using fuzzy system are the simplicity and ease of application, flexibility, speed and ability to deal with ambiguity and uncertainty. Due to accommodate and provide active and reactive energy in an active filter, it is not maintained at fixed voltage amplitude. In literature and used many of the control amplitude balancing devices, such as PI, PID, and fuzzy logic control. In this paper,

it uses fuzzy control capacity to achieve a balance between the DC voltage algorithms to improve the performance of the controller. The proposed method is evaluated and tested under the conditions of a sinusoidal voltage source is the use of MATLAB/SIMULINK software. UPQC performance depends on the characteristic of the active filters. Unit is used fuzzy logic control in almost all sectors of industry and energy systems, science, and one of them is the current harmonic and reactive power compensation [8]. In this way, both the existing network and load voltage are sinusoidal, thus, indicating they are also sinusoidal. Some writers applied this concept, using voltage source inverters in uninterruptible power supply in UPQC [9]. In [10], and this is called the concept of "dual topology unified air power quality" (iUPQC), and programs for controlling the use of the theory of the QQ, which requires identification in real time from a series of positive voltages and currents components. The aim of this project is to propose a simplified control technology for dual topology three stages of a unified power quality conditioner (iUPQC) for use in networks facilities. The development of the proposed control system in the frame of reference ABC and allows the use of classical control theory without the need to coordinate the implementation of transformers and digital control. And refers to both the Sudanese armed forces and PAFs are sinusoidal, dispense with the extraction of the harmonic current network and load voltage [11-13].

## II. APPLICATION EQUIPMENT

In order to clarify the applicability of control iUPQC improve depicts the electrical system with two buses in the spotlight, namely Bus A and Bus B bus is a bus slams energy supplied sensitive loads and serves as a coupling point and micro grid system. B bus is a bus for the micro grid, which is connected to the non-linear loads, requiring high quality power supply. Voltages at the bus A and B must be regulated, in order to provide true sensitive loads and nonlinear loads. The effects of harmonic currents from non-linear loads must be drawn mitigate, avoid propagating harmonic effort of a bus. STATCOM use to ensure voltage regulation in the bus is not enough because the harmonic currents from non-linear loads drawn are not diluted. On the other hand, UPQC or iUPQC between the bus and the bus

and B can compensate harmonic currents nonlinear loads and offset voltage in a bus B, in terms of effort harmonics, unbalance, and sag / swell. However, this is still not enough to ensure the voltage regulation in a bus A. Thus, to achieve all the desired goals, and STATCOM bus A and UPQC (or iUPQC) between the bus A and B should be used. However, the costs of this solution are unreasonably high.

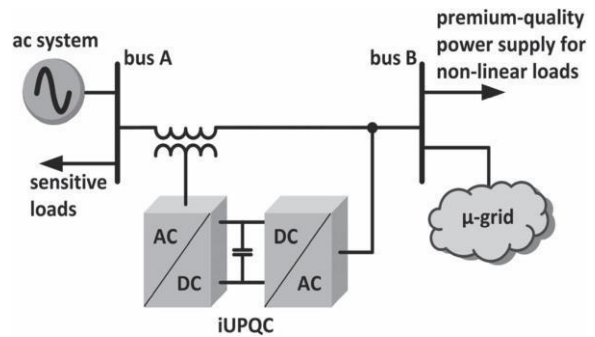


Fig.1. Example of applicability of iUPQC

Attractive solution would be to use and control unit iUPQC modified to provide support also reactive power Bus A, in addition to all of those functions of this equipment, as received. Note that iUPQC modified as intertie between the A and B buses. Moreover, the micro grid is connected to a bus B can be a complex system consists of generation distribution, system power management, and other surveillance systems involving micro grid, as well as the concepts of smart grid. In short, can the iUPQC amendment provide the following functionality?

- A) "Smart" circuit breaker as intertie between the grid and micro grid.
- B) Power control and power flow between the grid and micro grid (imposed by the higher control of micro grid) layer;
- C) Support the reactive power on a bus thousand of the power system;
- D) Support the voltage / frequency on the bus B of the micro grid.
- E) Voltage Harmonic current isolation between the bus A and bus b (synchronous network voltage and load current capability active filter);

**F) Effort and to compensate the current imbalance.**

According to the conventional control iUPQC, and converting Ext imposes a sinusoidal voltage-controlled bus B, which corresponds to the functions listed above (d). As a result, the conversion Ext has no degree more freedom to do the minimum conditions to compensate for active- or reactive power to expand its functions variables. On the other hand, to convert a series of traditional iUPQC uses only the active control variable r power, in order to assemble current basic sine derived from buses A, corresponding to the active power demanded by bus B.

If the capital link to and from iUPQC does not have a large energy storage system, or even a lack of the presence of an energy source, serving variable p controller is also active in power as additional reference to convert a string to keep the energy inside the capital of a link iUPQC balanced. In this case, the losses in iUPQC and active energy provided by converting Ext must compensate quickly in the form of additional active power injection before to convert a string to a bus B. And iUPQC can be as follows:

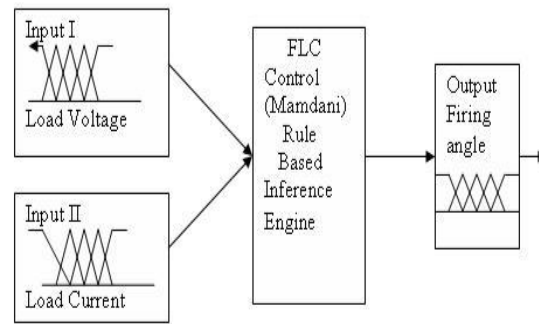
A) "Smart" circuit breaker as

B) The power flow between the grid and micro grid control unless the compensation references active-action and the power of the converter series can arbitrarily adjust. In this case, it is necessary to provide a source of energy (or large energy storage) associated with the link from the capital iUPQC. The degree of involvement of liberty by the variable represents control reactive power for converts a string of iUPQC. In this way, the iUPQC provide compensation reactive power to the bus like a STATCOM thousand of the network. As it will be confirmed, you can add this functionality to the controller without degrading all other functions of iUPQC.

**III. FUZZY LOGIC CONTROL**

A Zadeh's first paper on the theory of a mysterious group in 1965 since then, it has been the development of a new language to describe the mysterious properties of reality, which is very difficult and sometimes even impossible to be described using traditional methods. Fuzzy logic is a new control approach with great potential for real time applications

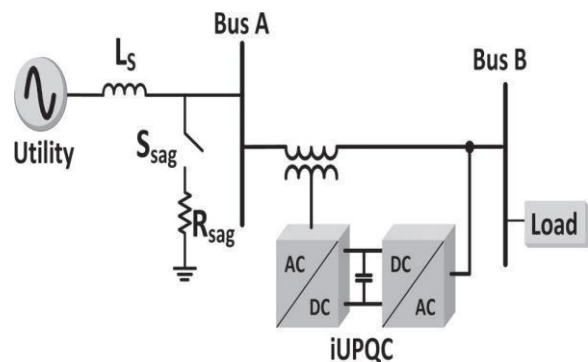
Fig.2 shows the structure of the fuzzy logic controller (FIS-Fuzzy inference system) in MATLAB Fuzzy logic toolbox to study the dynamic behavior of the converter. Load voltage and load current taken as input to fuzzy system. For a closed loop control, error input can be selected as current, voltage or impedance, according to control type. To get the linearity triangular membership function is taken with 50% overlap. The output of fuzzy controller taken as the control signal and the pulse generator provides synchronous firing pulses to thyristors. The Fuzzy Logic is a rule based controller, where a set of rules represents a control decision mechanism to correct the effect of certain causes coming from power system.



**Fig.2. Structure of fuzzy logic controller**

**Table I Iupqc Prototype Parameters**

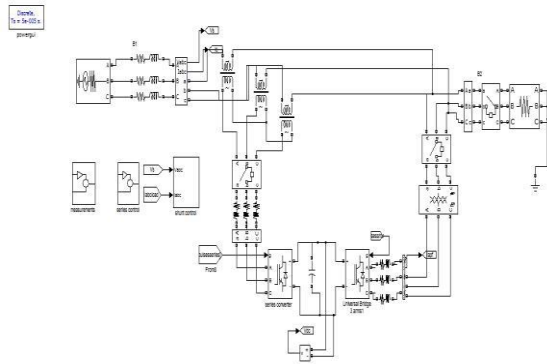
Parameter	Value
Voltage	220V rms
Grid Frequency	60HZ
Power Rate	5KVA
Dc-Link Voltage	450V DC
Dc-Link Capacitors	C=9400µF



**Fig.3. iUPQC experimental scheme**

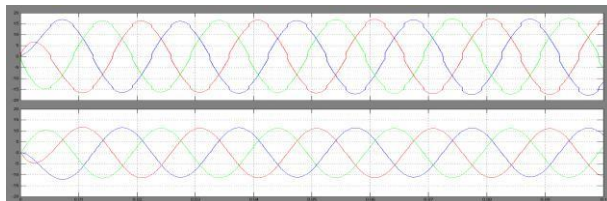
**IV. EXPERIMENTAL RESULTS**

In order to verify all the power quality issues described in this paper, the iUPQC was connected to a grid with a voltage sag system, so for that first we consider no load condition.

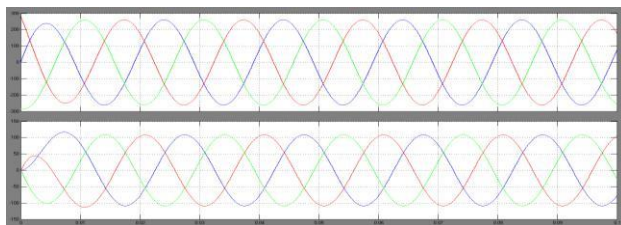


**Fig.4. MatLab/Simulink diagram of modified iUPQC**

Fig.4 shows the simulation diagram of iUPQC. In that disturbances are occurred. This disturbance occurs due to use of power electronics devices.



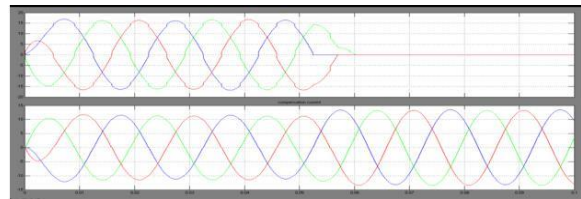
**(a)**



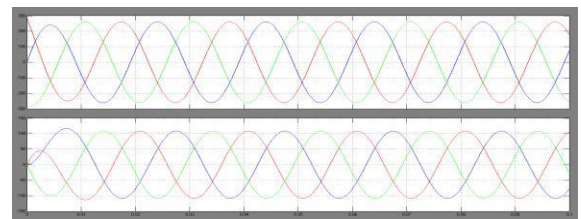
**(b)**

**Fig.5. iUPQC responses at no load condition: (a) Load current and compensated current (b) Grid voltages and currents**

Now, we consider second condition that is iUPQC transitory response during the connection of a two phase diode rectifier with non linear load



**(a)**

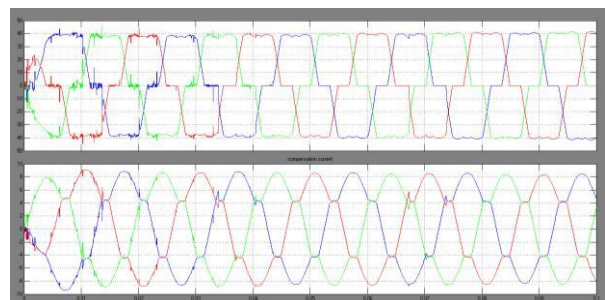


**(b)**

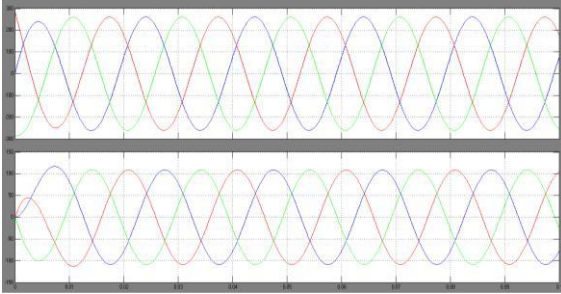
**Fig.6. iUPQC transitory response during the connection of a two-phase diode rectifier: (a) Load current and compensated current (b) Grid voltages and currents**

iUPQC performance during the connection of two phase diode rectifier with non linear load is, in order to better verify the mitigation of power quality issues. The diode rectifier has the same dc and the same voltage sag.

Now we consider third condition in that iUPQC transitory response during the connection of a three phase diode rectifier with non linear load.



**(a)**



(b)

**Fig.7. iUPQC transitory response during the connection of a three phase diode rectifier: (a) Load current and compensated current (b) Grid voltages and currents**

### V.CONCLUSION

Power-quality related issues are mitigated with the help iUPQC using Fuzzy logic control new technology. This new feature of the iUPQC provides new solutions in future scenarios like micro grids, including distributed generation and energy storage systems to better deal of renewable energy resources .The addition of one more power-quality compensation feature, the grid-voltage regulation .The experimental results verified the improved iUPQC goals. The grid-voltage regulation was achieved with no load, as well as nonlinear load. These results have demonstrated a suitable performance of voltage regulation at both sides of the iUPQC, even while compensating harmonic current and voltage imbalances

### REFERENCES

- 1) K. Karanki, G. Geddada, M. K. Mishra, and B. K. Kumar, "A modified three-phase four-wire UPQC topology with reduced DC-link voltage rating," *IEEE Trans. Ind. Electron.*, vol. 60, no. 9, pp. 3555–3566, Sep. 2013.
- 2) V. Khadkikar and A. Chandra, "A new control philosophy for a unified power quality conditioner (UPQC) to coordinate load-reactive power demand between shunt and series inverters," *IEEE Trans. Power Del.*, vol. 23, no. 4, pp. 2522–2534, Oct. 2008.
- 3) K. H. Kwan, P. L. So, and Y. C. Chu, "An output regulation-based unified power quality conditioner with Kalman filters," *IEEE Trans. Ind. Electron.*, vol. 59, no. 11, pp. 4248–4262, Nov. 2012.
- 4) Mokhtatpour and H. A. Shayanfar, "Power quality compensation as well as power flow control using of unified power quality conditioner," in *Proc. APPEEC*, 2011, pp. 1–4.

- 5) J. A. Munoz et al., "Design of a discrete-time linear control strategy for a multi cell UPQC," *IEEE Trans. Ind. Electron.*, vol. 59, no. 10, pp. 3797–3807, Oct. 2012.
- 6) V. Khadkikar and A. Chandra, "UPQC-S: A novel concept of simultaneous voltage sag/swell and load reactive power compensations utilizing series inverter of UPQC," *IEEE Trans. Power Electron.*, vol. 26, no. 9, pp. 2414–2425, Sep. 2011.
- 7) V. Khadkikar, "Enhancing electric power quality using UPQC: A comprehensive overview," *IEEE Trans. Power Electron.*, vol. 27, no. 5, pp. 2284–2297, May 2012.
- 8) L. G. B. Rolim, "Custom power interfaces for renewable energy sources," in *Proc. IEEE ISIE*, 2007, pp. 2673–2678.
- 9) N. Voraphonpipit and S. Chatratana, "STATCOM analysis and controller design for power system voltage regulation," in *Proc. IEEE/PES Transmiss. Distrib. Conf. Exhib.—Asia Pac.*, 2005, pp. 1–6.
- 10) J. J. Sanchez-Gasca, N. W. Miller, E. V. Larsen, A. Edris, and D. A. Bradshaw, "Potential benefits of STATCOM application to improve generation station performance," in *Proc. IEEE/PES Transmiss. Distrib. Conf. Expo.*, 2001, vol. 2, pp. 1123–1128.

### Author's Profile

**Mr.M.BHASKER** is presently working as Assistant professor in Samskruti College of Engineering and technology, Ghatkesar, Rangareddy, Telangana, India. He received the B. Tech degree in Electrical & Electronics Engineering from Sri Indu College of Engineering & Technology, JNTUH, and then completed M.Tech in Electrical & Electronics Engineering with EPS specialization at J. B. Institute of Engineering and Technology, JNTUH. He has a teaching experience of 1 year.His areas of interest are Power System, Power Quality, Electrical Machines, Switchgear and Protection

**MS. CH.MANJULA** is presently working as Assistant professor in Princeton Institute of engineering & Technology for Women, Narapally, Rangareddy, Telangana, India. She received B.Tech degree in Electrical and Electronics Engineering from Bhoj Reddy Engineering College for Women, JNTUH, and then completed M.Tech in Electrical & Electronics Engineering with EPS specialization at J. B. Institute of Engineering and Technology, JNTUH. She has a teaching experience of 1 1/2 year.Her areas of interest are Power System, Electrical Machines, Power Quality, Switchgear and Protection.