

Rise of Internet of Things (IoT) in Agricultural Sector

¹Krishnamurthy Ramasubramanian, ²S. Vamshi Krushna

^{1,2} Assistant Professor., Department of CSE,

^{1,2} Samskruti College of Engineering and Technology,

Kondapur (V), Ghatkesar (Mdl), Medchal (Dist)

Hyderabad

Abstract - The term Internet of Things or simply IoT first appeared on the Web around 2004, but reached the height of its popularity by the end of 2013 (Google Trends, 2016). The Internet of Things (IoT) is a vital universal information network consisting of internet-connected objects, such as Radio-frequency identification (RFIDs), sensors, actuators, as well as other instruments and smart appliances that are becoming an integral component of the future internet. Recently, these search terms have declined in popularity on the general Web, but gained more momentum among various fields. Modern Dictionaries included the definition of IoT as "the interconnection via the Internet of computing devices embedded in everyday objects, enabling them to send and receive data." The idea and concept behind IoT is not a new thing; it evolved from the Machine to Machine (M2M) systems and what a few companies called the Industrial Internet (Lopez, 2015). Currently, IoT applications are everywhere, from smart homes, smart connected cars, smart cities, smart businesses, and smart agricultural environments. This survey is intended to serve as a guideline and conceptual framework for future research to enhance the Agricultural sector with the help of IoT technology and to motivate and inspire further developments. It also provides a systematic exploration of existing research and suggests a number of potentially significant research directions.

Index Terms—Internet of things, industry solutions, smart wearable, smart home, smart city, smart environment, smart enterprise, smart farm fields, IoT marketplace, IoT products.

1. INTRODUCTION

The Internet of Things (IoT) is an interconnection of networks where, typically, an enormous number of objects / things / sensors / devices are connected through communications information infrastructure to provide value-added services. The term was first

coined in 1998 and later defined as "The Internet of Things allows people and things to be connected Anytime, Anyplace, with anything and anyone, ideally using any path/ network and any service" [1]. As highlighted in the definition, connectivity among the devices is a critical functionality that is required to fulfill the vision of the IoT. The main reasons behind such interest are the capabilities and sophistication that the IoT will bring to society [2]. It promises to create a world where all the objects around us are connected to the Internet and communicate with each other with minimal human intervention. The ultimate goal is to create "a better world for human beings", where objects around us know what we like, what we want, and what we need, and hence act accordingly without explicit instructions [3]. IoT is not only about new technological devices or platforms, such as sensors, integrated systems and embedded systems, but according to IBM Watson (2016), it is the ability to "collect data from things and make value from it" for smart farm fields, farmers and consumers. Agriculture remains a critically important part of Global economy. With some estimates showing an expected doubling of our world population by 2050, farmers will need to dramatically increase not only the amount of land devoted to farming but also the yields these farms can create. At the same time, they will need to reduce the amount of water used to grow these crops. Today, 70% of the fresh water consumed in Universe is used in farming. By deploying systems to monitor the moisture in soil at various depths and reporting this back to a central irrigation management system, field tests have shown that water consumption can be cut from 10 to 30% depending on the crops and the soil. This equates to saving more water than households consume every year. By not over-watering or under-watering, yields can also be increased by up to 7%. In addition to irrigation management, remote sensing helps with the measurement of soil health, pH, and other characteristics, which a farmer can then use to make decisions about where fertilizer is needed and

exactly how much to apply. Optimizing these two inputs improves crop economics, and reduces unneeded irrigation or fertilizer applications. Now a day's many agricultural industries turned to adopt IoT technology for smart farming to enhance productivity, efficiency, global market and other features such as minimization of human efforts, time and cost etc. The Advancement in the technology ensures that the sensors are getting smaller, sophisticated and more economic. The networks are also available and it can be accessed easily across the world so that smart farming can be achieved with full pledge. Focusing on encouraging innovation in agriculture, smart farming is the answer to the problems that this industry is currently facing. All this can be done using smart phones and IoT devices. Farmer can get any required data or information as well able to monitor his agricultural sector.



IOT SOLUTIONS FOR SMART AGRICULTURE

The most critical issues that arise in Agricultural industry are erratic changes in weather condition. The number of effects of weather change includes heavy rainfall, most intense storm and heat waves, draught conditions etc. Due to these the productivity reduces drastically. To increase the productivity and reduces difficulties in agriculture field, there is need to use modern network technology and techniques called Internet of Things. Today, the Internet of Things (IoT) is moving towards agricultural sector and enabling farmers to compete with the enormous challenges they face. Farmers can get huge information and knowledge about various aspects of agriculture which includes

Soil Management:

Soil management is a integral activity of measuring soil quality and monitoring soil moisture level. It is possible to use IoT for both these management activities.

i) Measuring Soil Quality:

A system that monitors changes in soil quality could be used for three major purposes.

- a) A system can be used to track the soil quality by using soil quality indicators, resource surveys and assessments.
- b) A system can improve the management of soil conservation programs by aiding in setting tolerable soil erosion standards, targeting lands that need conservation measures, and identifying lands most suitable for inclusion in long-term easement programs.

- c) A system of soil quality indicators can aid in the analysis of the sustainability of farming systems by providing a set of criteria against which farming systems can be compared.

The indicator attributes can then be used in simple models to predict a soil's ability to perform its three primary functions.

Reference and Measured Values of Minimum Data Set for a Hypothetical Typic Hapludoll Soil

Horizon and Characteristic	Reference Value	Measured Value
Surface horizon Phosphorus (mg/kg)	30	15
Potassium (mg/kg)	300	300
Organic carbon (percent) Total	2	1.5
Labile	0.2	0.15
Bulk density (mg/m ³)	1.3	1.5
pH	6.0	5.5
Electrical conductivity (S/m)	0.10	1.0
Texture (percent clay)	30	32
Subsoil horizon Texture (percent clay)	35	35
Depth of root zone (m)	1.0	0.95
Bulk density (mg/m ³)	1.5	1.5
pH	5.5	5.5
Electrical conductivity (S/m)	0.10	0.10

Landscape-level assessments – use satellite and remote sensing technology to assess resource quality at

Large spatial scales. Using remote sensing to predict soil carbon storage is one possible use for this type of assessment. This information is shared among various agricultural devices through IoT and the same is communicated to farmer's community.

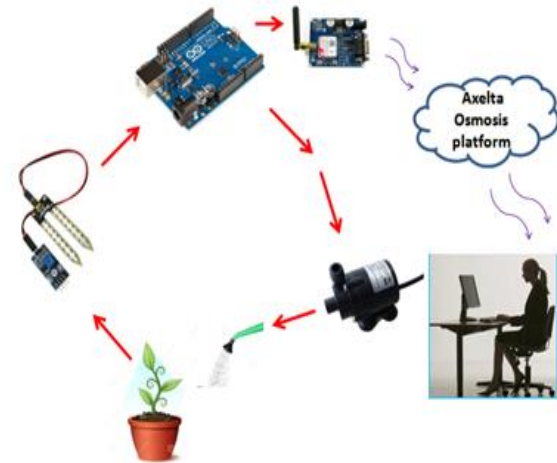
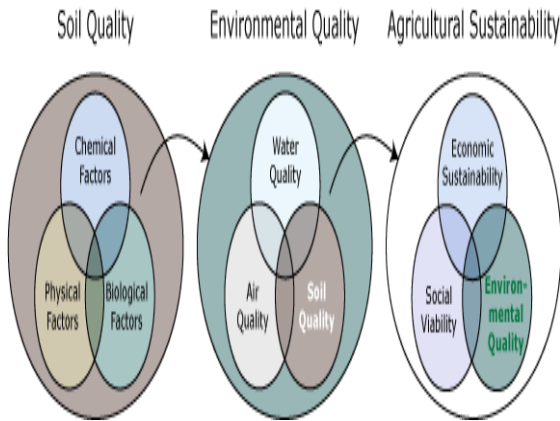

ii) Monitoring of Soil Moisture:

The moisture level plays an important role in the irrigation process as the fields can be saved from excessive watering and also from deficiency of water. For this, the system uses GSM modem (for sending data to the cloud and the user) interfaced to the microcontroller. GSM modem with a SIM card implements the communication technique as in a regular cell phone. The system makes use of AVR microcontroller (Arduino UNO), soil moisture sensor. It is programmed to receive the input signal of varying moisture condition of the soil. The system is powered by a dc 5V.

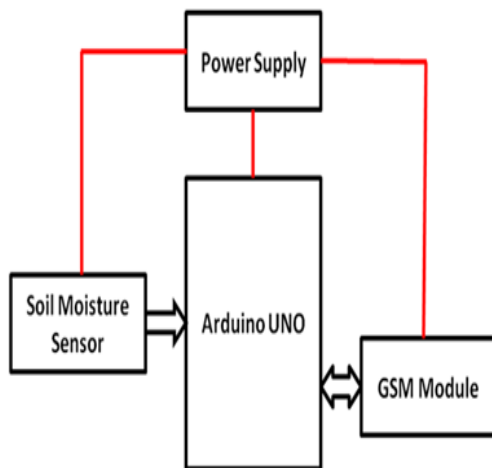

Water Management:

Smart water management is important to manage water resources efficiently. The Internet of Things (“IoT”) can help the water supply from various sources like rain, underground water etc., to be used more efficiently and with less wastage. Smart water meters are a form of IoT, a network of technologies which can monitor the status of water resource objects, capture water resource full data, and communicate that data over a wireless network to a software application for analysis on a computer in the cloud. Modern IoT Systems are having capability of contiguous monitoring various devices such as smart water meters and other smart electronic devices. It also analyze natural environmental elements such as a ground area for finding moisture and chemical content level. A smart device is associated with each object which provides the connectivity and a unique digital identity for identifying, tracking and communicating with the object. A sensor within or attached to the device is connected to internet by a local area connection (such as RFID, NFC or BTLE) and can also have wide area connectivity. Typically, each data transmission from a device is small in size but the number of transmissions can be frequent. Each sensor will monitor a specific condition or set of conditions such as vibration, motion, temperature, and pressure or water quality. More applications have become possible because of less cost and size of such devices continues to decrease and their sophistication for measuring conditions keeps increasing.

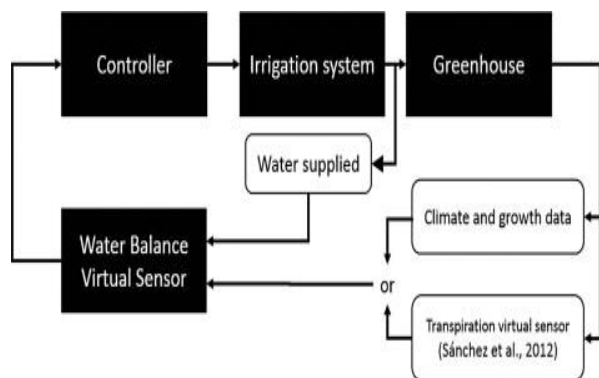

Proposed water management model:

The Common Communication interface is composed by a set of web services that are consumed by applications belonging to the Management - Exploitation layer, in order to operate on entities defined by the physical model, identify the current state of the systems and also send water management operations to control the water consume.

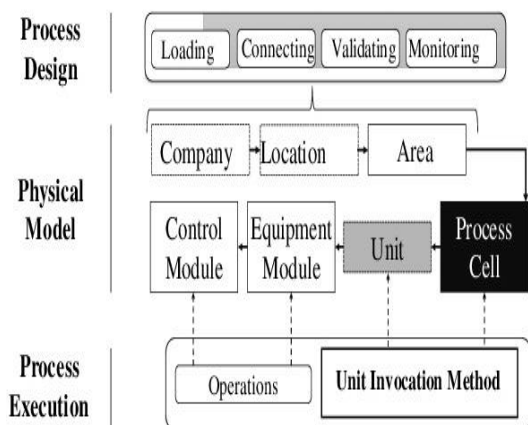

Control of Insecticides & Pesticides and Crop monitoring:

In world many of the countries on average loses over 2.0 million cotton bales every year due to the cotton leaf curl virus (CLCV), which is considered to be the one of the top reasons for low cotton yield. CLCV is a deadly virus that is transmitted by a small insect called white fly: a sucking pest of cotton and vegetables. Similarly, recently, a new problem, generally known as 'reddening' or 'red-leaf-disease' is now becoming a serious problem in various cotton crops especially in Asian Countries. We believe that technology could help the farmers to monitor different types of

Parameter timely and cost effectively. There have been several studies of IoT in agriculture for general parameter monitoring in pest control. It boosts their output as is shown by the fact that many countries are using it and benefiting from it. Wireless sensor network (WSN) has proved to be very useful in specific applications requiring monitoring of real time data. Precision agriculture is among one of them. Recently the agriculture domain has incorporated WSN to support its major monitoring operations. Pest detection and control is at least as old as agriculture because there has always been a need to keep crops free from pests. Various techniques are proposed for pest control in agriculture using IoT. In this part of the paper we will review and present different types of proposed mechanisms and techniques and analyze the research work of different authors and compare the relative advantages and disadvantages. Table I illustrate crops and their related pest which are reviewed in literature.

CROP VS PEST

CROP	PEST/ Disease
<i>Cocos Nucifera L</i>	RPW Larvae ^[16]
Grapes	<i>Downy Mildew</i> ^[4]
Sugar Cane	Shoot borer, Rood borer ^[5]
Groundnut	Vectors (e.g. <i>Thrips</i>) ^[8]
Green houses	RPW ^[14]
Date Palm Tree	Red Date Palm Weevil (RDPW) ^[18]
Vineyard	North American leafhopper ^[19]
Ivy Geranium, Impatiens	Two spotted spider mites (TSM: <i>Tetranychus urticae</i>) ^[27]

Image sensors are used for monitoring and capturing pest, it is a low-cost system based on battery powered wireless image sensors, which are able to capture and send images of pesticides and insecticides to a remote control system with specific frequency demanded by pest control application. These image sensors accurately monitor quantity of pest with a higher temporal resolution.

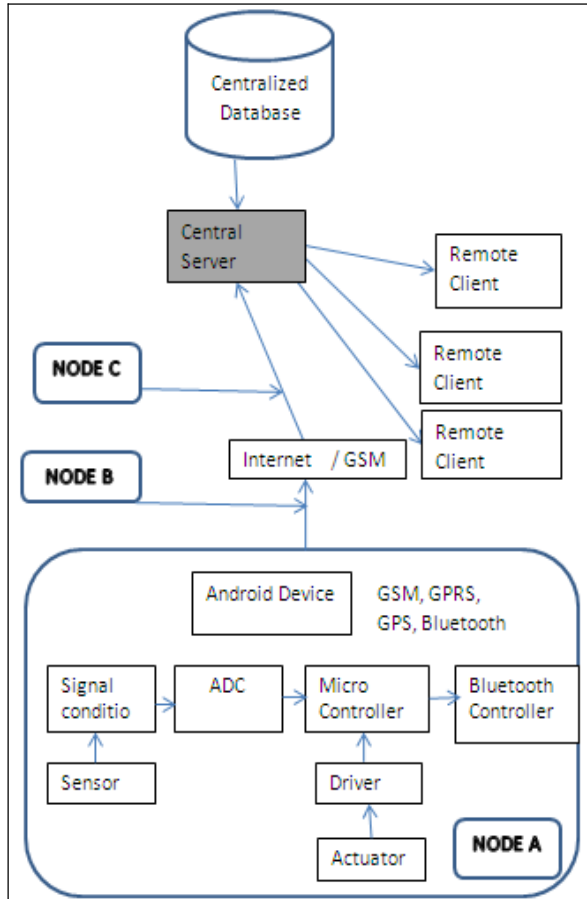

With the help of latest electronics and information technologies, scope of using infrared lights integrated with sensing systems for optimized crop monitoring and production. Latest development in this field is the introduction of wireless sensor network for monitoring pest and precision agriculture. Timely and accurate information concerning the spatial inconsistency within crops is very important. Sensing technology for pest and disease detection is most advanced and can provide the data required for site specific management.

Conclusion and Future Work:

This paper presented a survey of the IoT solutions for implementing smart agriculture. We classified the solutions, in the field of agriculture broadly into four categories: Soil Management, Water Management, Crop Monitoring and Control of Insecticides & Pesticides. Role of IoT in agricultural field is increasing day by day due to advancement in various technologies like cloud computing, sensors and varius

Electronic devices. In particular, sensors and actuators are getting increasingly powerful, less expensive and smaller, which makes their use ubiquitous. This paper reviews the recent researches on IoT from Soil management perspective. We firstly introduce the background of measuring Soil quality and Soil moisture. We use SOA models of IoT and then discuss the fundamental technologies that might be used in IoT. Next, we introduce some key agricultural applications of IoT. We also examined the contribution of each solution for improving the efficiency and effectiveness of Smart Agriculture. We have considered physical model, which defines the physical elements executing water management processes in a hierarchical method, and also, the process model, which organizes and maintain the execution of particular processes in water management subsystems. We also reviewed pest control literature and classify control mechanism as non-technological, technological and integrated pest and actuators are getting increasingly powerful, less expensive and smaller, which makes their use ubiquitous. This paper reviews the recent researches on IoT from Soil management perspective. We firstly introduce the background of measuring Soil quality and Soil moisture. We use SOA models of IoT and then discuss the fundamental technologies that might be used in IoT. Next, we introduce some key agricultural applications of IoT. We also examined the contribution of each and actuators are getting increasingly powerful, less expensive and smaller, which makes their use ubiquitous. This paper reviews the recent researches on IoT from Soil management perspective. We firstly introduce the background of measuring Soil quality and Soil moisture. We use SOA models of IoT and then discuss the fundamental technologies that might be used in IoT. Next, we introduce some key agricultural applications of IoT. We also examined the contribution of each solution for improving the efficiency and effectiveness of Smart Agriculture. We have considered physical model, which defines the physical elements executing water management processes in a hierarchical method, and also, the process model, which organizes and maintain the execution of particular processes in water management subsystems. We also reviewed pest control literature and classify control mechanism as non-technological, technological and integrated pest management. It reduces human efforts, simplifies techniques of farming and helps to gain smart farming. Along with these features smart farming can help to grow the market for farmer with single touch and minimum efforts.

The below table gives information about various mechanisms proposed for pest control.

Pest control Mechanisms in literature using WSN and IoT

Papers / Authors	Analysis of Symptoms	Identification of Pests	Management Pest
Sarika Datir 2014 [4]	Real time system that detect Downy Mildew pest based on weather data.	No identification mechanism.	Spraying of pesticides automatically if disease Probability is Severed.
K Tripathy 2013 [8]	Weekly data collected manually	No identification mechanism. Specific crop, pest and disease.	Real time decision support system for prediction of disease
O. Lopez 2012 [14]	Schedule image captured.	No identification mechanism	Removal of pest by Traps.
N Shirivastav 2013 [16]	Continuously observe the noise level being collected by the various sensors and comparator that is set to a particular threshold level	No identification mechanism for specifying pest.	An alarm signal to turn inform the operator and farmer can then take the necessary measures to spray insecticides
Srinivas 2013 [17]	Acoustic activities of larvae i.e. chewing, crawling, emission and quick oscillating sounds.	Comparison of detected noise / sound with prerecorded sound of RPW.	No control measures are mentioned.
Mohammad A. Al-Manie 2007 [18]	Acoustic emissions produced by the RDPW inside the date palm tree were successfully Recorded And identified using special sensor.	Comparison of detected noise / sound with prerecorded sound of RPW.	Isolating or treating the infected trees with appropriate chemicals.
Mauro Prevostini 2011 [19]	Real time prototype data collection and based on weather data assume that diseasevector is spreading. Which will use the temperature readings to simulate the spread of the disease vector	No identification of pest mechanisms exists.	Pesticide, when it is absolutely necessary,.

References

- Morais, Raul, A. Valente, and C. Seródio. "A wireless sensor network for smart irrigation and environmental monitoring: A position article." In 5th European federation for information technology in agriculture, food and environment and 3rd world congress on computers in agriculture and natural resources (EFITA/WCCA), pp.45-850. 2005.
- Agrawal, Sarita, and Manik Lal Das. "Internet of Things—A paradigm shift of future Internet applications." In Engineering (NUICONe), 2011 Nirma University International Conference on, pp.1-7. IEEE, 2011.
- Hu, Xiangyu, and Songrong Qian. "IoT application system with crop growth models in facility agriculture." In 2011 6th International Conference on Computer Sciences and Convergence Information Technology ICCIT. 2011.
- Li, Li, Hu Xiaoguang, Chen Ke, and He Ketai. "The applications of WiFi-based wireless sensor network in internet of things and smart grid." In Industrial Electronics and Applications ICIEA, 2011 6th IEEE Conference on, pp. 789-793. IEEE, 2011.
- Tuli, Anupriya, Nitasha Hasteer, Mukesh Sharma, and Ankur Bansal. "Framework to leverage cloud for the Modernization of the Indian agriculture system." In Electro/Information Technology (EIT), 2014 IEEE International Conference on, pp. 109-115. IEEE, 2014.
- Liu, Yuxi, and Guohui Zhou. "Key technologies and applications of internet of things." In Intelligent Computation Technology and Automation (ICICTA), 2012 Fifth International Conference on, pp. 197-200. IEEE, 2012.
- Zhao, Ji-chun, Jun-feng Zhang, Yu Feng, and Jian-xin Guo. "The study and application of the IOT technology in agriculture." In Computer Science and Information Technology ICCSIT, 2010 3rd IEEE International Conference on, vol. 2, pp. 462-465. IEEE, 2010.
- Jhuria, Manoj, Ajit Kumar, and Rushikesh Borse. "Image processing for smart farming: Detection of disease and fruit grading." In Image Information Processing (ICIIP), 2013 IEEE Second International Conference on, pp.21-526. IEEE, 2013.
- González-Andújar, José Luis. "Expert system for pests, diseases and weeds identification in olive crops." Expert Systems with Applications 36, no. 2, pp 3278-3283, 2009.
- TongKe, Fan. "Smart Agriculture Based on Cloud Computing and IOT." Journal of Convergence Information Technology 8, no. 2, 2013.
- Chen, Xian-Yi, and Zhi-Gang Jin. "Research on key technology and applications for internet of things." Physics Procedia 33, pp. 561-566, 2011.

- 12) Talpur, Mir Sajjad Hussain, Murtaza Hussain Shaikh, and Hira Sajjad Talpur. "Relevance of Internet of Things in Animal Stocks Chain Management in Pakistan's Perspectives." International Journal of Information and Education Technology 2, no. 1, 2012.
- 13) Evangelos A, Kosmatos, Tselikas Nikolaos D, and Boucouvalas Anthony C. "Integrating RFIDs and smart objects into a UnifiedInternet of Things architecture." Advances in Internet of Things 2011, 2011.
- 14) Carvin, Denis, Philippe Owezarski, and Pascal Berthou. "Managing the upcoming ubiquitous computing." In Proceedings of the 8th International Conference on Network and Service Management, pp. 1276-280. International Federation for Information Processing, 2012.
- 15) Prasad, Rajkishore, Kumar Rajeev Ranjan, and A. K. Sinha. "AMRAPALIKA: An expert system for the diagnosis of pests, diseases, and disorders in Indian mango." Knowledge-Based Systems, Vol. 19, no. 1, pp. 9-21,2006.
- 16) Sarma, Shikhar Kr, Kh Robindro Singh, and Abhijeet Singh. "An Expert System for diagnosis of diseases in Rice Plant." International Journal of Artificial Intelligence, Vol. 1, no. 1 ,pp. 26-31,2010.
- 17) Da Xu, Senior Member, IEEE, Wu He, and Shancang Li Internet of Things in Industries: A Survey, IEEE TRANSACTIONS ON INDUSTRIAL INFORMATICS, VOL. 10, NO. 4, NOVEMBER 2014.

Author Profile:



Krishnamurthy Ramasubramanian
Assistant. Professor., Department of CSE,
Samskruti College of Engineering and
Technology, Kondapur (V), Ghatkesar (Mdl),
Medchal (Dist)-Hyderabad



Vamshi Krushna S Assistant.
Professor., Department of CSE,
Samskruti College of Engineering and
Technology, Kondapur (V), Ghatkesar
(Mdl), Medchal (Dist)-Hyderabad